

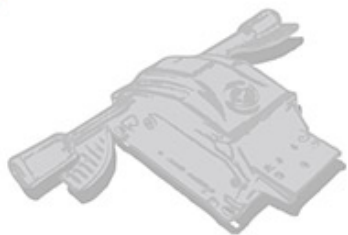

TEC[®]

TECview Group Co., Ltd

德芝寶實業



德芝寶實業有限公司

成立於1989年，公司設立之初為代理德國SUSPA公司之辦公椅氣壓棒，工業用之氣壓棒及油壓棒。目前以辦公椅配件、工業用氣壓棒...等產品為主；並提供整合、倉儲、物流服務項目



研發



接受少量訂購



快速交貨



產品多樣



品質控管



供應網

TEC
TECview Group Co.,Ltd
德芝寶實業

目錄

扶手



p.01-p.10

底盤



p.11-p.18

氣壓棒



p.19-p.23

椅腳



p.24-p.32

椅輪



p.33-p.36

塑膠框



p.37-p.49

網布

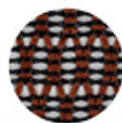

p.50-p.55

其它辦公椅配件

p.56

氣壓棒



p.57-p.59

阻尼器



p.60

軸承



p.61-p.62

接頭



p.63-p.65

01

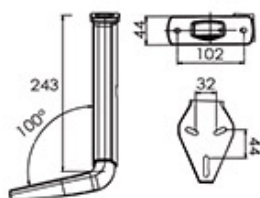
**WS-138**

材質:尼龍+纖
升降段數:31段
裝箱數:30pcs

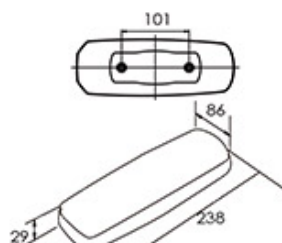
**WS-07TPU**

材質:TPU
裝箱數:80pcs

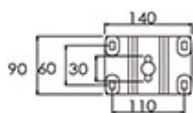
**WS168**

材質:尼龍+纖
裝箱數:100pcs
適用於WS調整型扶手

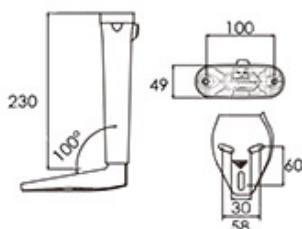

H626

材質:尼龍+纖
升降段數:10段
裝箱數:20pcs

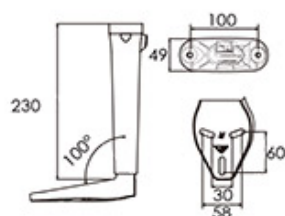

H626-1

材質:尼龍+纖
升降段數:10段
裝箱數:20pcs

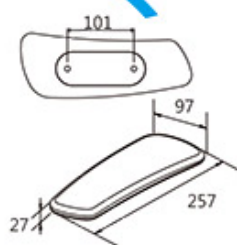

PU1828

材質:PU
裝箱數:40pcs

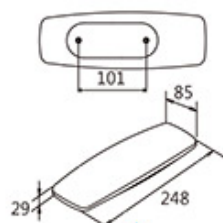

PU1829

材質:PU
裝箱數:40pcs

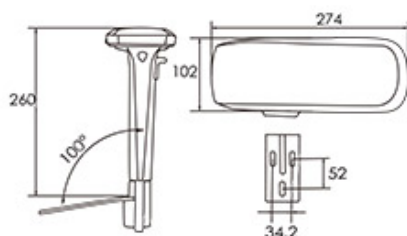

H634S1
+PU1834-4

材質-支架:尼龍+纖+鐵+鋁

-扶手墊:PU+鐵

裝箱數:16pcs

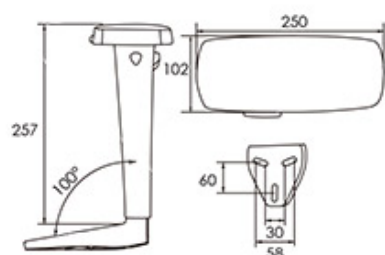

H626-4
+PU1834S

材質-支架:尼龍+纖

-扶手墊:PU+鐵

裝箱數:20pcs

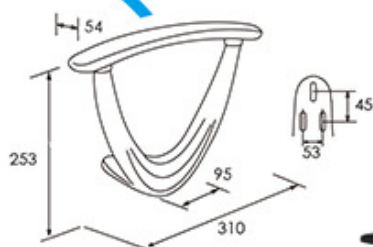

CH-161PP

材質:PP

裝箱數:20pcs

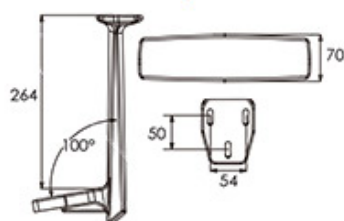

CH-180

材質:PP

裝箱數:20pcs



鋁合金材質

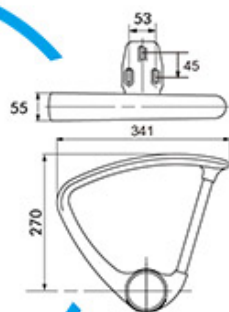

CH-163NAPP

材質:PP+鋁合金

裝箱數:16pcs



鋁合金材質

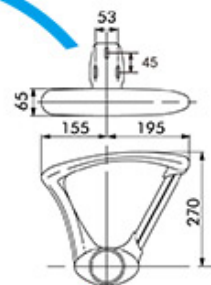

CH-172APP

材質:PP+鋁合金

裝箱數:16pcs

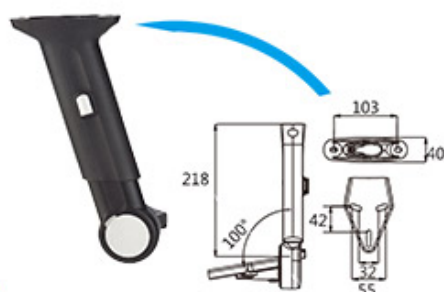

WS-112

材質:尼龍+纖
升降段數:6段
裝箱數:24pcs



WS-123S

材質:尼龍+纖
升降段數:6段
裝箱數:30pcs



WS-122T

材質:尼龍+纖
+熱塑性橡膠
升降段數:9段
裝箱數:22pcs

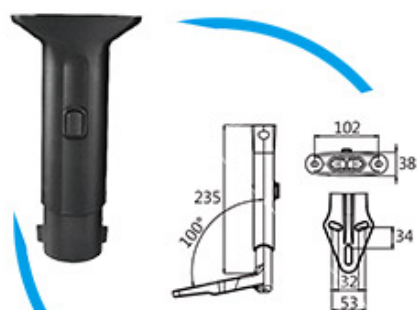

WS-126

材質:尼龍+纖
升降段數:7段
裝箱數:36pcs

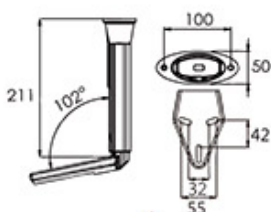

內藏式按鈕

**WS-158**

材質:尼龍+纖

段數:9段

裝箱數:36pcs

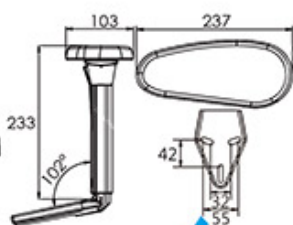

內藏式按鈕

**WS-158FT**材質:尼龍+纖
+熱塑性橡膠

段數:9段

裝箱數:20pcs

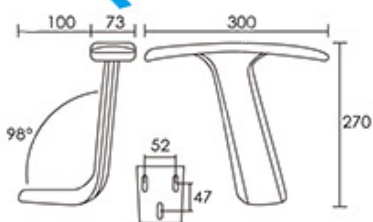
**WS-378**

材質:PP

裝箱數:24pcs

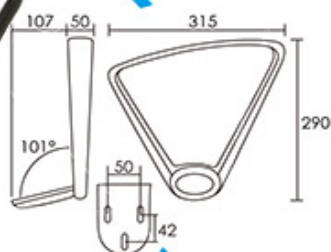
**WS-358S**

材質:PP

裝箱數:16pcs

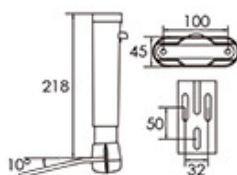
AT-03A

材質:PP+鋁合金+鐵

段數:6段

裝箱數:10pcs

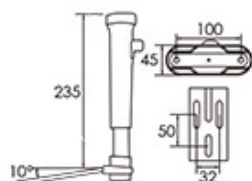
AT-15

材質:PP+鐵

段數:7段

裝箱數:10pcs

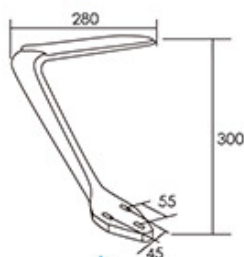
JS-099

材質:鋁合金+PU

裝箱數:3對





09

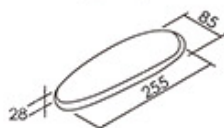
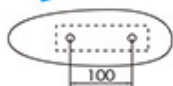

D190

材質:PU

裝箱數:40pcs

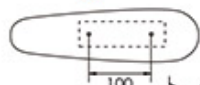

D65-1

材質:PU

裝箱數:40pcs

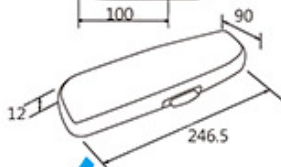
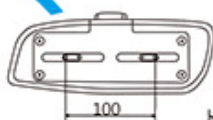

WS801-2D

材質:PU

裝箱數:30pcs

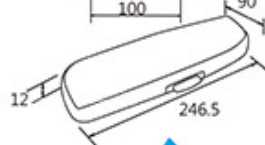
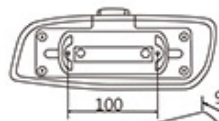

WS801-3D

材質:PU

裝箱數:24pcs

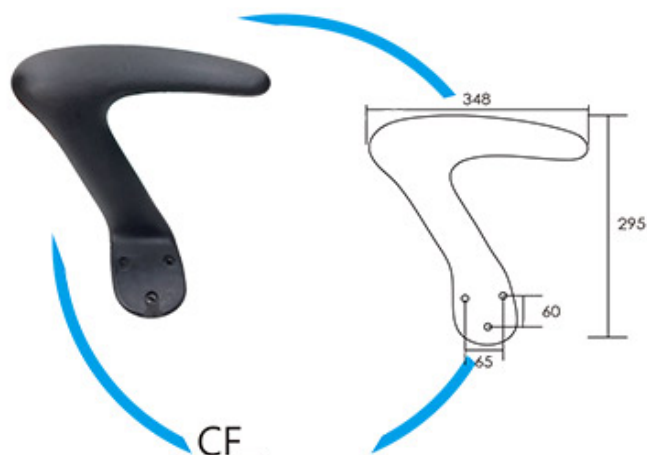

CF

材質:PU

裝箱數:10pcs

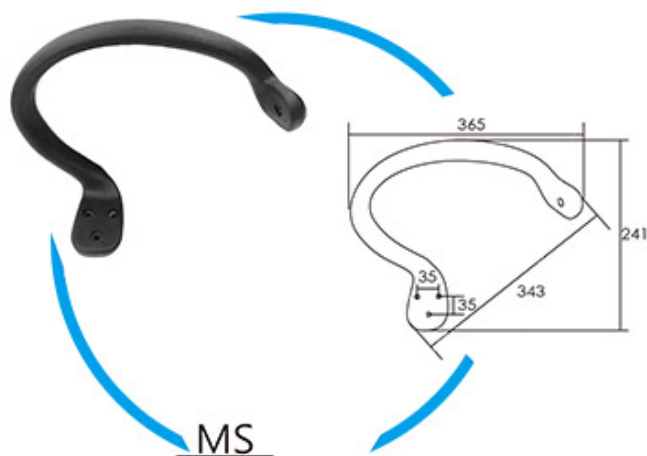

MS

材質:PU

裝箱數:10pcs

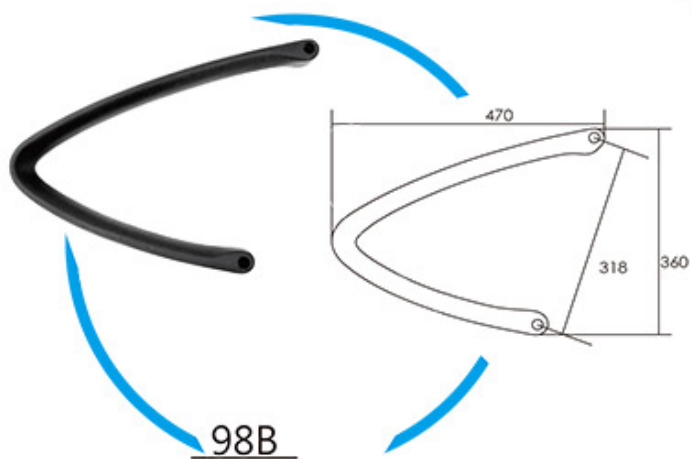

98B

材質:PU

裝箱數:10pcs



滑動控制

傾仰鎖定

11 升降控制



傾仰鬆緊



T738A

- 分離式傾仰四段鎖定底盤
- 具有安全回彈功能
- 底板厚度3mm
- 椅背調節角度90°~110°
- 可滑動58mm

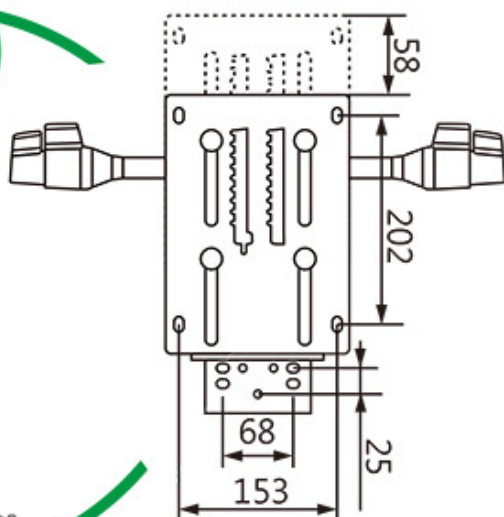

傾仰鎖定



傾仰鬆緊



升降控制

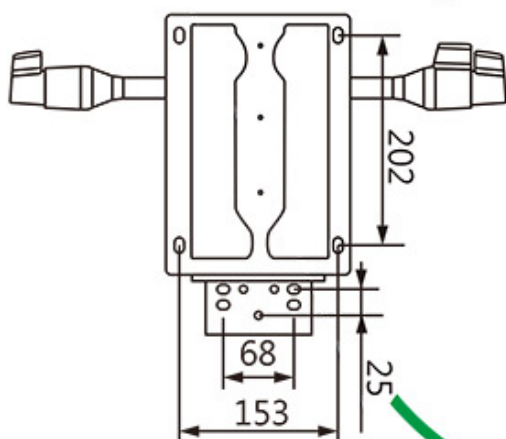

T738C

- 分離式傾仰四段鎖定底盤
- 具有安全回彈功能
- 底板厚度3mm
- 椅背調節角度90°~110°



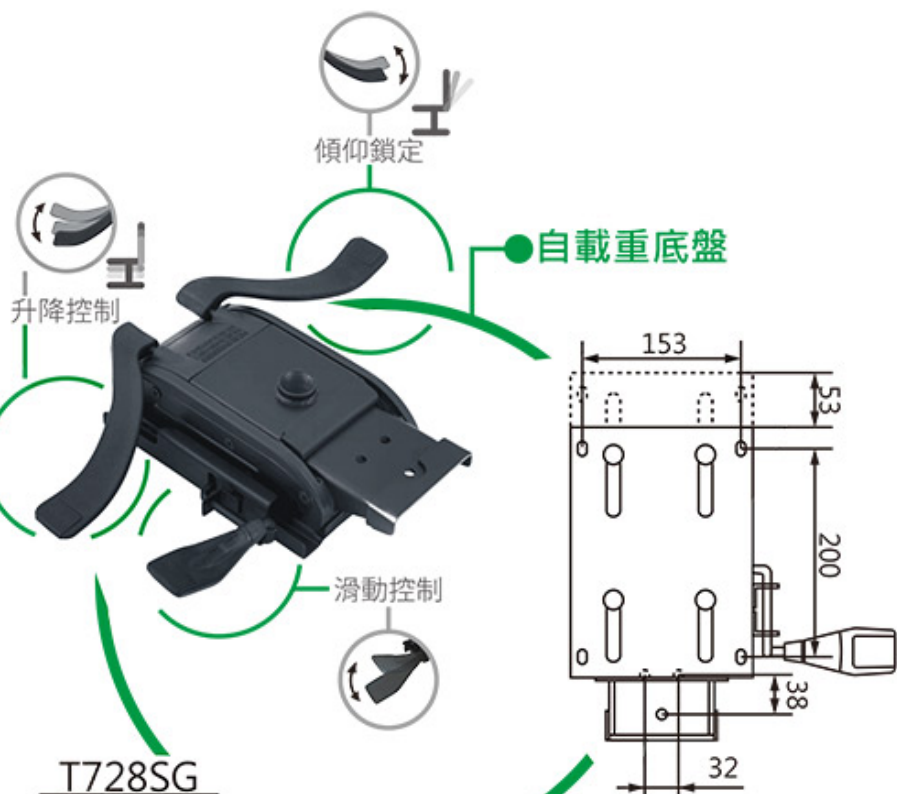

T728SG

- 分離式傾仰五段鎖定底盤
- 具有安全回彈功能
- 底板厚度3mm
- 椅背調節角度 $90^{\circ} \sim 108^{\circ}$
- 可滑動53mm



T728A/T728B

- 分離式傾仰五段鎖定底盤
- 具有安全回彈功能
- 底板厚度3mm
- 椅背調節角度 $90^{\circ} \sim 108^{\circ}$



13

升降控制

傾仰鎖定

●簡易型自載重底盤

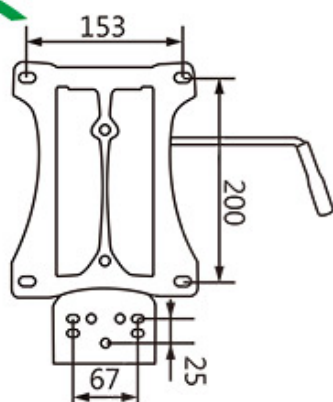
**T727B**

- 分離式傾仰二段鎖定底盤
- 具有安全回彈功能
- 底板厚度2.5mm
- 椅背調節角度90°~108°

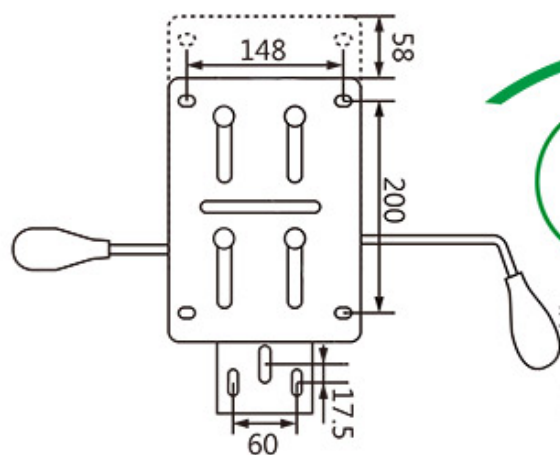

傾仰鬆緊



滑動控制

升降控制 傾仰控制

T879SD

- 分離式傾仰底盤
- 底板厚度3.5mm
- 椅背調節角度87°~106°
- 可滑動58mm/五檔鎖定

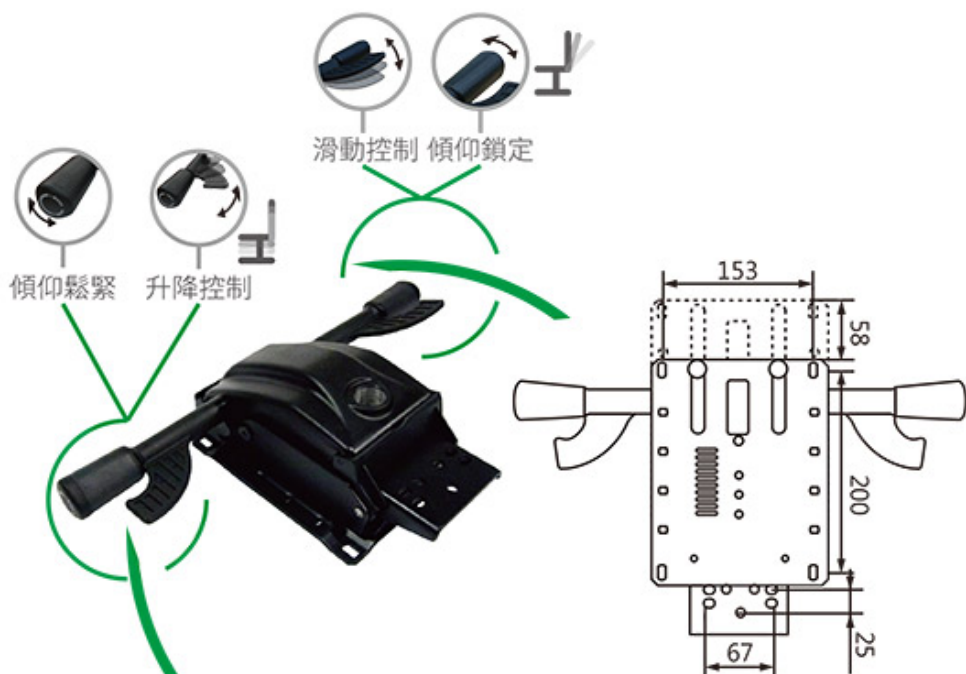

T718A

- 分離式四段鎖定傾仰底盤
- 具有安全回彈功能
- 底板厚度3mm
- 椅背調節角度 $90^{\circ} \sim 112^{\circ}$
- 可滑動58mm



T722A

- 同步傾仰四段鎖定底盤
- 具有安全回彈功能
- 底板厚度3mm
- 椅背調節角度 $0^{\circ} \sim 18^{\circ}$



傾仰鬆緊

傾仰鎖定



鋁合金材質

15



升降控制

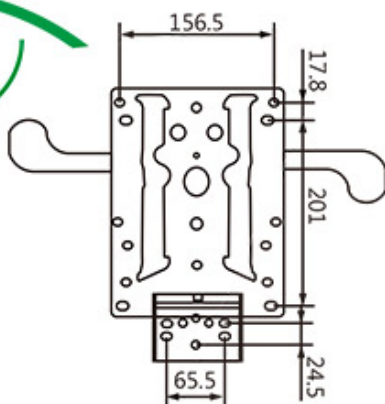

T701W

- 分離式五段鎖定傾仰底盤
- 具有安全回彈功能
- 底板厚度3mm
- 椅背調節角度90°~110°



傾仰鬆緊

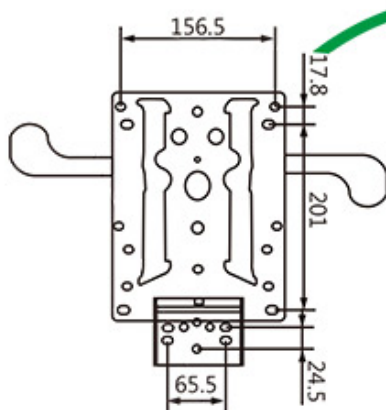

升降控制



傾仰鎖定



T711A

- 分離式五段鎖定傾仰底盤
- 具有安全回彈功能
- 底板厚度3mm
- 椅背調節角度90°~110°



傾仰鬆緊

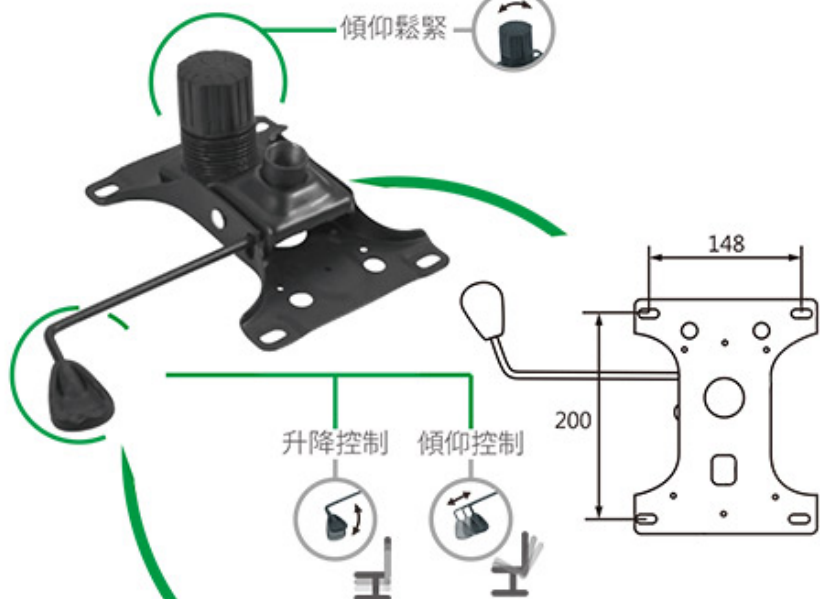

升降控制 傾仰控制

**T892**

- 氣壓傾仰底盤
- 底板厚度2.5mm
- 底座調節角度3°~16°

傾仰鬆緊

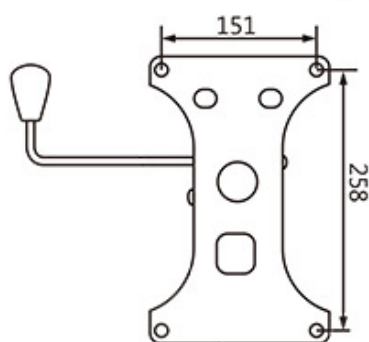

升降控制 傾仰控制

**T878-7**

- 氣壓傾仰底盤
- 底板厚度2.5mm
- 調節角度3°~25°

產品特色

底盤

同步傾仰
/單段鎖定

T878-7

分離式傾仰
/單段鎖定

T879D-Z

分離式傾仰
/夾片無段式鎖定

T879-CSF

分離式傾仰
/五段式鎖定

T711A

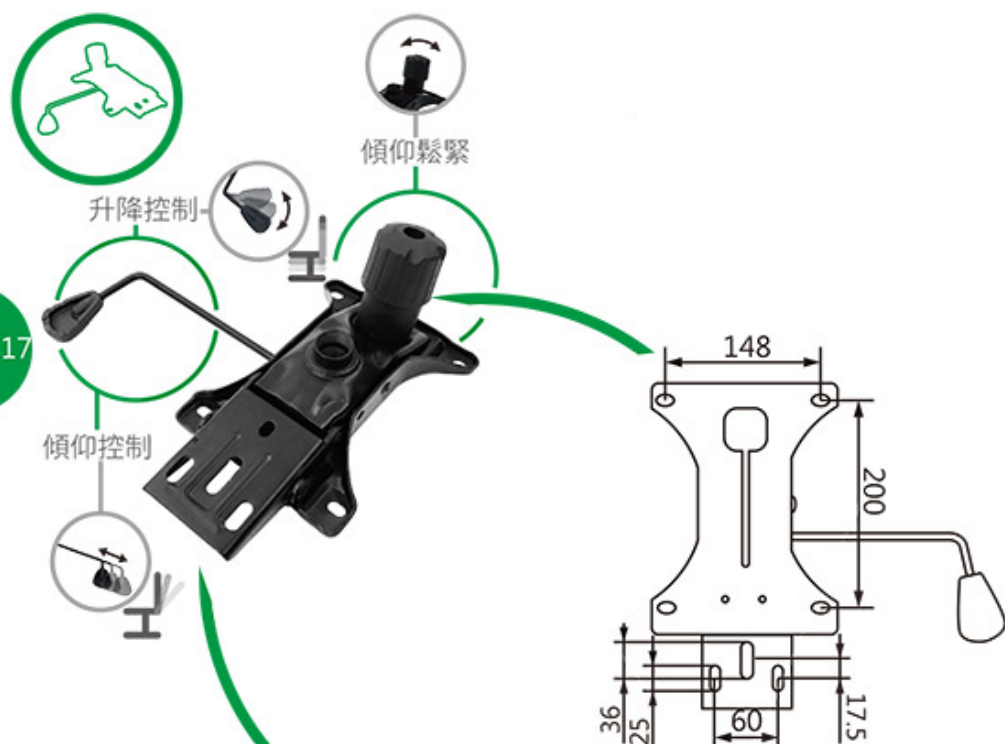
**T879D-Z**

- 分離式傾仰底盤
- 底板厚度3mm
- 椅背調節角度 $87^{\circ}\sim 106^{\circ}$

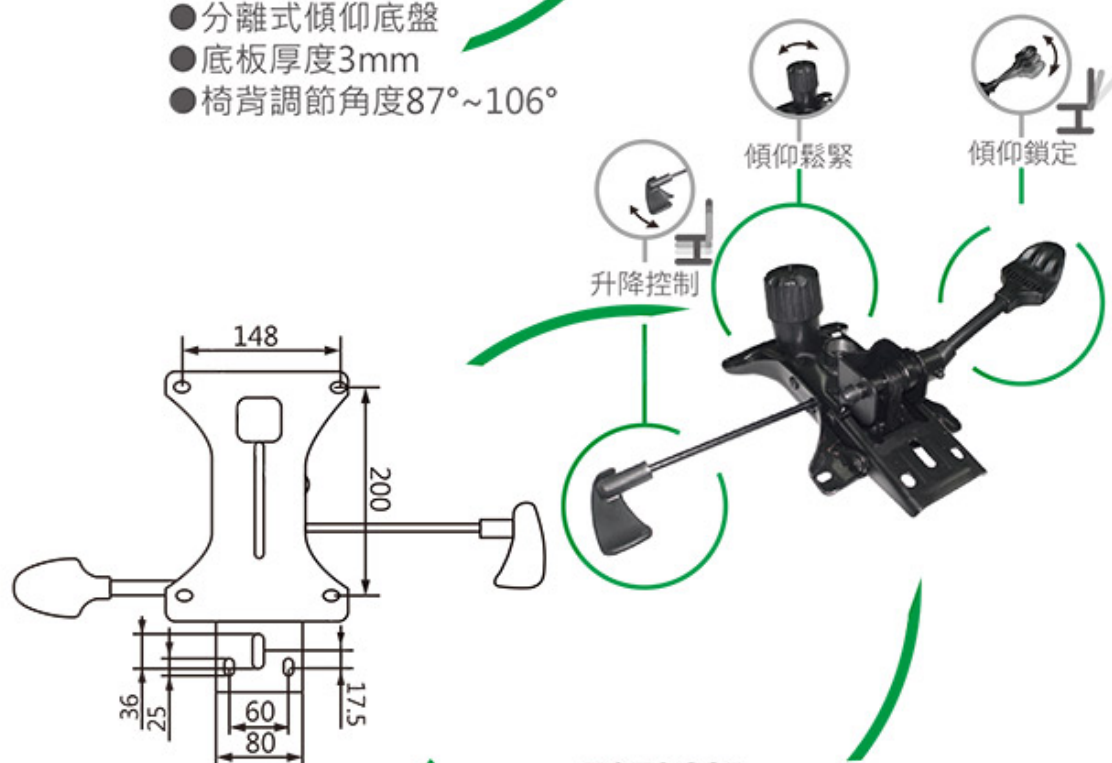
**T879CSF**

- 分離式無段鎖定傾仰底盤
- 底板厚度3mm
- 椅背調節角度 $87^{\circ}\sim 106^{\circ}$



升降控制

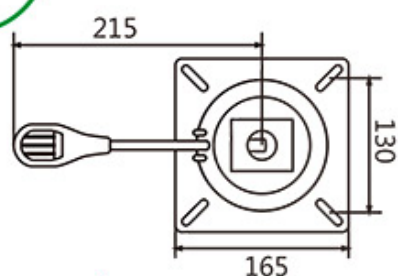

傾仰鎖定

四方盤

- 氣壓升降底盤
- 底板厚度2.3mm
- 平板為0°/-2.5°

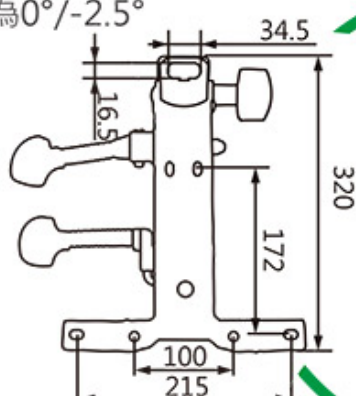

背管鬆緊



T322

- 氣壓傾仰底盤
- 底板厚度2.5mm
- 底座調節角度84°~117°



傾仰控制



傾仰鬆緊



升降控制

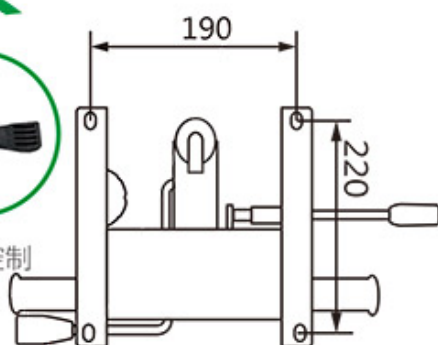

HL-025

- 同步傾仰底盤
- 底板厚度2.75mm
- 調節角度0°~18°



常規氣壓棒尺寸

19



65mm 行程
壓力470N



85mm 行程
壓力410N



100mm 行程
壓力350N

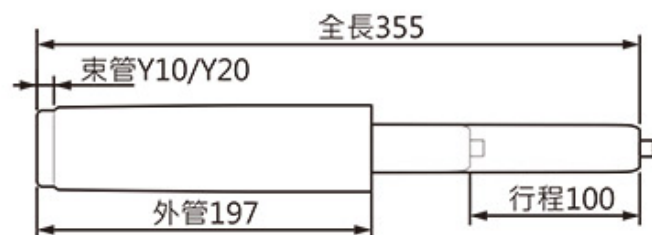

常規氣壓棒尺寸



120mm 壓力310N
行程



140mm 壓力310N
行程



200mm 壓力310N
行程

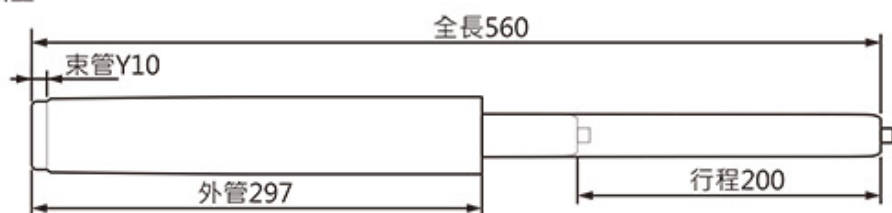

260mm 壓力310N
行程

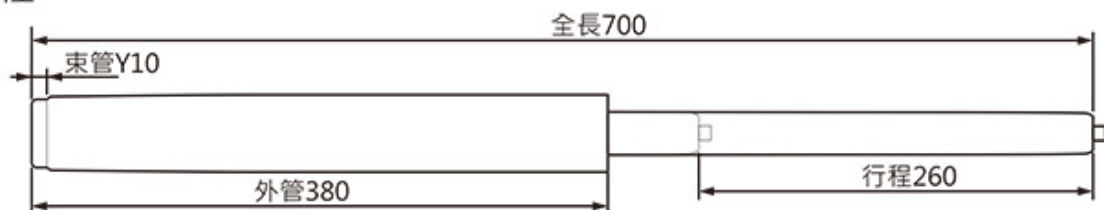



自動回位氣壓棒 (無升降)

21

- 自動迴旋復位，不帶升降功能
- 360°平滑無噪音旋轉
- 起身後，椅身自動回位，讓空間整齊一致
- 適用於銀行洽談椅、吧台椅

規格	全長L	外管V
AR240	240	160
AR260	260	180
AR275	275	195
AR295	295	215

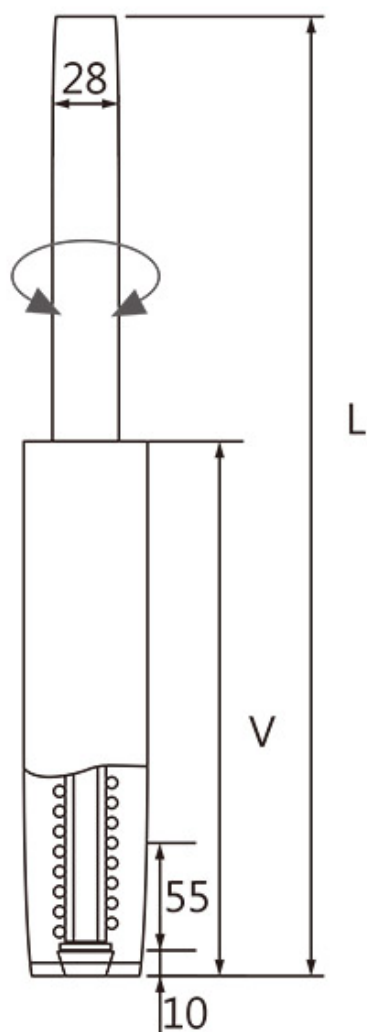

銀行洽談椅



吧台椅





350N

自動回位氣壓棒 ARG 50 (帶升降)

- 自動迴旋復位，帶升降功能
- 360°平滑無噪音旋轉
- 起身後，椅身自動回位，讓空間整齊一致
- 適用於兒童成長椅、銀行洽談椅、吧台椅

兒童成長椅



銀行洽談椅



吧台椅

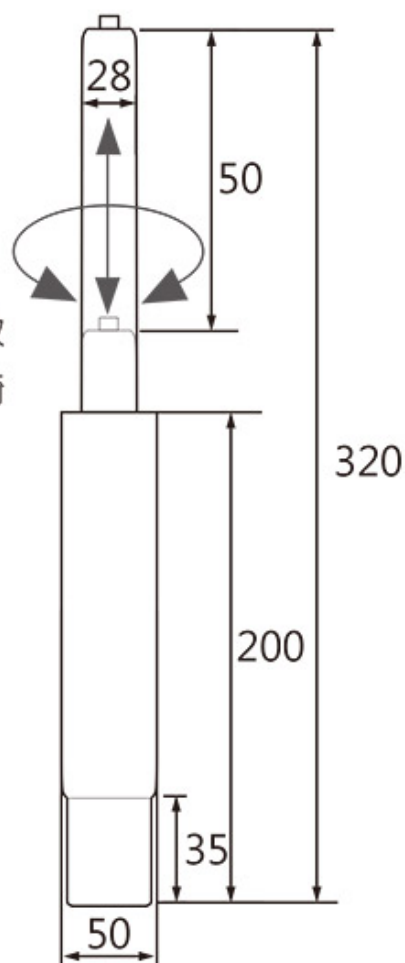



不旋轉氣壓棒

23

- 只能升降，不能旋轉
- 尺寸與常規氣壓棒通用
- 適用於兒童成長椅、吧台椅

兒童成長椅



吧台椅

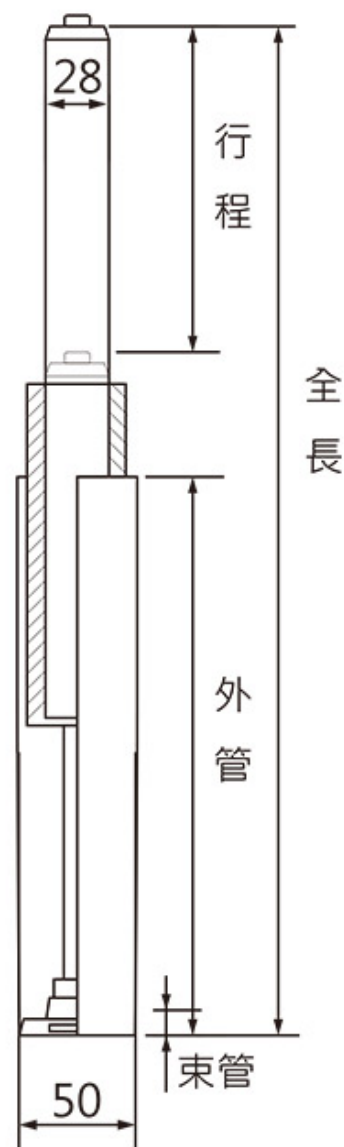

產品特色

氣壓棒

已通過以下單位測試

德國認證Class等級測試單位



Genau. Richtig.

旋轉測試單位

SGS

氣壓棒等級之分

Class 1-R=270mm
 Class 2-R=340mm
 Class 3-R=370mm
 Class 4-R=400mm

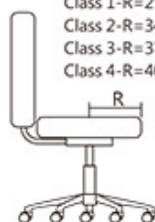

德芝寶
氣壓棒

Class 2

1.5mm厚的棒芯+1.2mm厚的外管

Class 3

2.0mm厚的棒芯+1.5mm厚的外管

Class 4

2.5mm厚的棒芯 (氮化處理) +1.5mm厚的外管

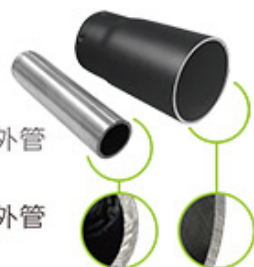



X350

材質:鋁合金
表面:拋光處理



P350

材質:鋁合金
表面:拋光處理



I300

材質:鋁合金
表面:拋光處理

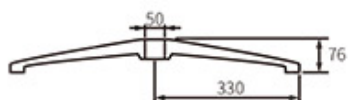

AL-B330

材質:鋁合金
表面:拋光處理

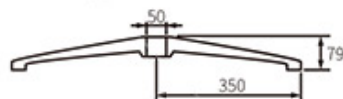

B350/L350

材質:鋁合金
表面:拋光處理

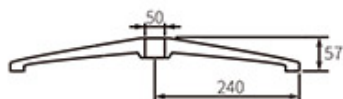

AL-C19

材質:鋁合金
表面:拋光處理



AL-D300

材質:鋁合金
表面:拋光處理



AL-H300

材質:鋁合金
表面:拋光處理



AL-S325B

材質:鋁合金
表面:拋光處理



27

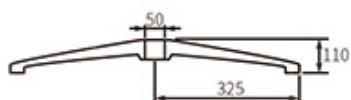

AL-J330

材質:鋁合金
表面:拋光處理

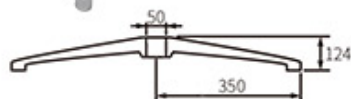

AL-S350

材質:鋁合金
表面:拋光處理

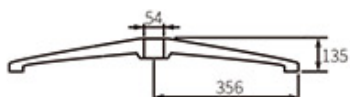

AL-H350

材質:鋁合金
表面:拋光處理

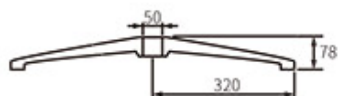

C320

材質:鋁合金
表面:拋光處理

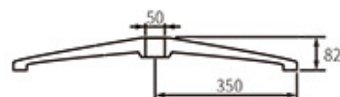

AL-350

材質:鋁合金
表面:拋光處理

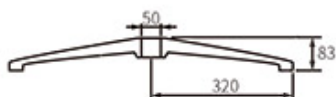

AL-R320

材質:鋁合金
表面:拋光處理



29

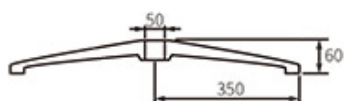

AL-X350

材質:鋁合金
表面:拋光處理

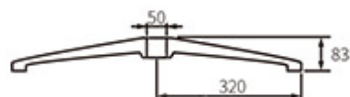

AL-320電鍍

材質:鋁合金
表面:電鍍處理

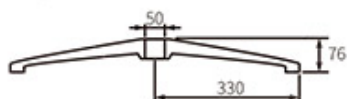

AL-B330電鍍

材質:鋁合金
表面:電鍍處理

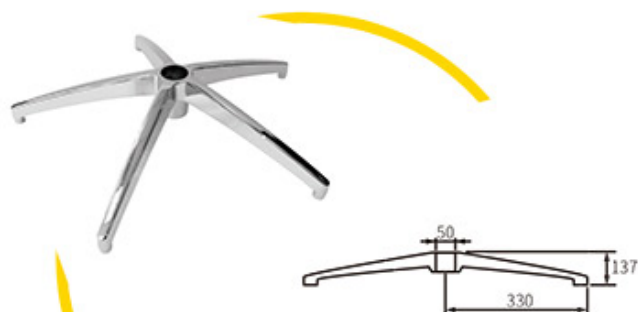

AL-S325B電鍍

材質:鋁合金
表面:電鍍處理



AL-S350電鍍

材質:鋁合金
表面:電鍍處理



SM320鐵腳

材質:鐵
表面:鍍鉻處理



1.扣壓式開關

2.旋轉鎖緊
更加牢固



圓管腳圈

材質:鐵+鋁合金

表面:電鍍+烤漆處理

可承重:136kg



1.扣壓式開關

2.旋轉鎖緊
更加牢固



扁管腳圈

材質:鐵+PP

表面:烤漆處理

可承重:136kg





460腳圈

材質:鐵+鋁合金

表面:鍍鉻+噴塑處理



510腳圈

材質:鐵+鋁合金

表面:鍍鉻+噴塑處理



5005BUG-E

輪徑:50mm
材質:尼龍+PU
單顆載重:35KG

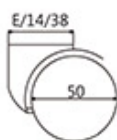

5006BUG-38

輪徑:50mm
材質:尼龍+PU
單顆載重:35KG

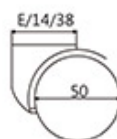

6001GUB-23

輪徑:60mm
材質:尼龍+PU
單顆載重:35KG

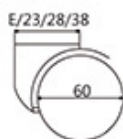

6005BUB-38

輪徑:60mm
材質:尼龍+PU
單顆載重:35KG

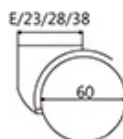

6506BUDG-23

輪徑:65mm
材質:尼龍+PU
單顆載重:50KG

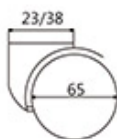



6005BUB-23-C

輪徑:60mm
材質:尼龍+PU
單顆載重:35KG

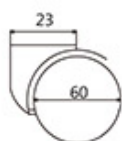

5006BUG-38SB

坐下不動

輪徑:50mm
材質:尼龍+PU
單顆載重:35KG



5003B-14BKL

輪徑:50mm
材質:尼龍
單顆載重:35KG

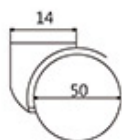

6001BUG-E BK

輪徑:60mm
材質:尼龍+PU
單顆載重:35KG

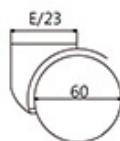
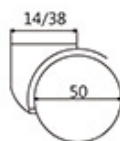

6005GUB-23BK

輪徑:60mm
材質:尼龍+PU
單顆載重:35KG

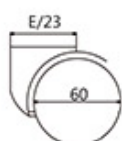



5003B-38-C

輪徑:50mm
材質:尼龍
單顆載重:35KG

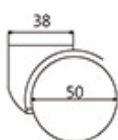

5003B-38

輪徑:50mm
材質:尼龍
單顆載重:35KG

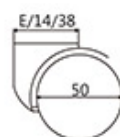

5505B-23

輪徑:55mm
材質:尼龍
單顆載重:35KG

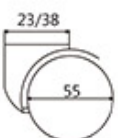

6001B-23

輪徑:60mm
材質:尼龍
單顆載重:35KG

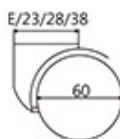

6506B-23

輪徑:65mm
材質:尼龍
單顆載重:50KG

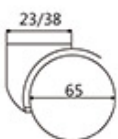



5006BUG-38P

輪徑:50mm
材質:尼龍+PU
單顆載重:35KG

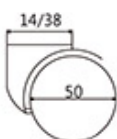

6506BUB-23P

輪徑:65mm
材質:尼龍+PU
單顆載重:50KG

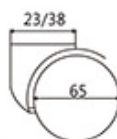

65F1GUBL-23

輪徑:65mm
材質:尼龍+PU
單顆載重:50KG

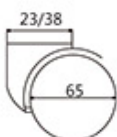

客制化LOGO輪

輪徑:65mm
材質:尼龍+PU
單顆載重:50KG

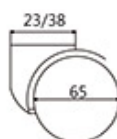

- 1.提升品牌·杜絕模仿
- 2.客製化文字圖案
- 3.少量接單
- 4.Logo一體成型永不脫落·不退色
- 5.Logo顏色與PU一致·多種色彩可挑選(藍/綠/紅/灰/黃)

36

產品特色

PU 輪

常規輪片顏色



PU可選顏色



上芯尺寸

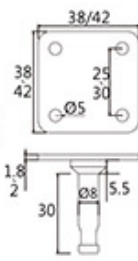
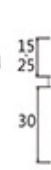
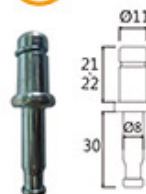



MADE IN TAIWAN
台灣設計研發、生產製造

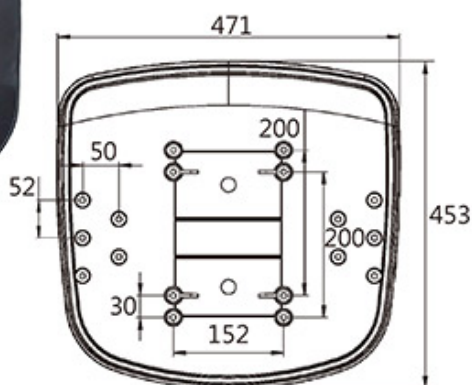

CY 座板

材質：PP加纖

☞ 不含空氣污染毒物

SGS 可通過測試

🌱 保護樹木 愛惜地球

♻️ 可回收材質

(符合美國ANSI/VIFMA X5.1-2011 一般用途辦公椅試驗)

- 落下試驗-動態
- 旋轉試驗-循環
- 座椅耐久試驗
- 扶手強度試驗-水平-靜態
- 扶手強度試驗-垂直-靜態
- 扶手耐久性試驗-循環

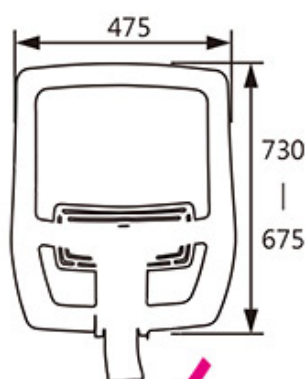

五段高低調整

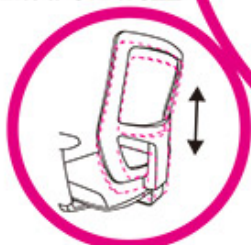

APOLLO高背

材質:尼龍+30%玻纖

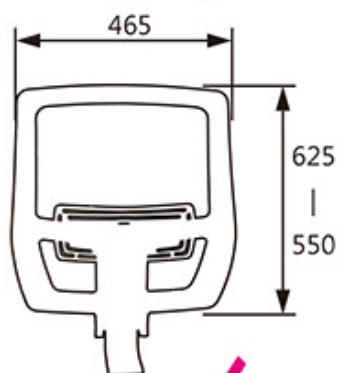

五段高低調整

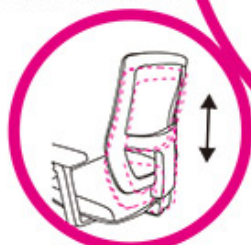

APOLLO中背

材質:尼龍+30%玻纖

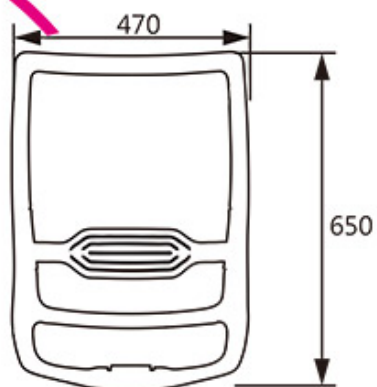

B817
材質:尼龍+織

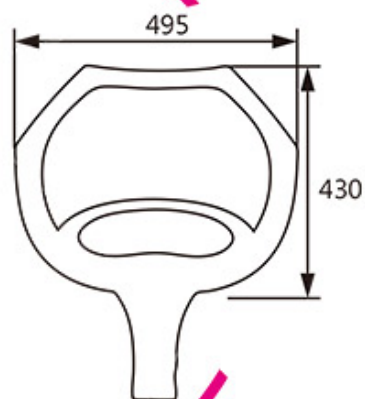

HH-01
材質:PP

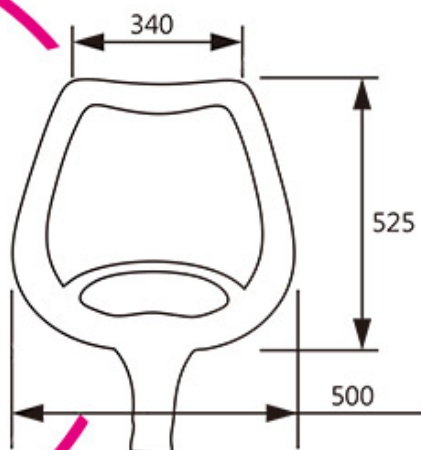

HH-02
材質:PP

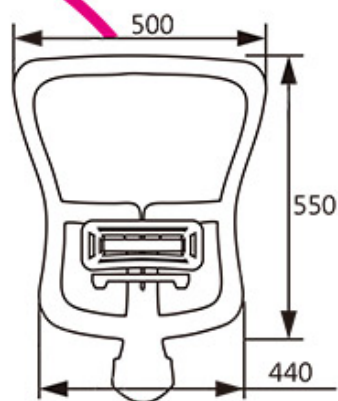

HC-B02
材質:PP/尼龍

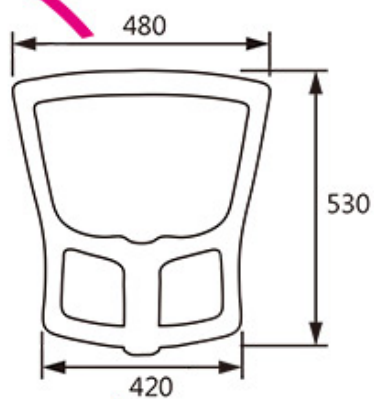

HC-183
材質:尼龍

41

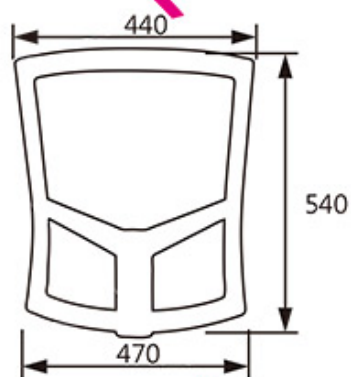

HC-189
材質:尼龍

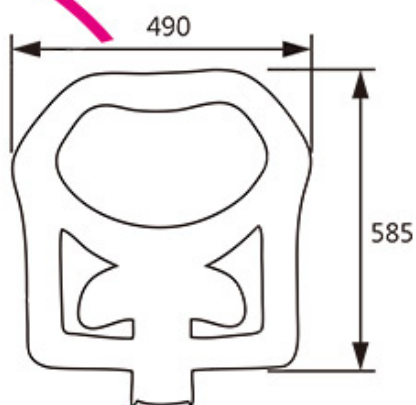

WJ-001
材質:尼龍+PP

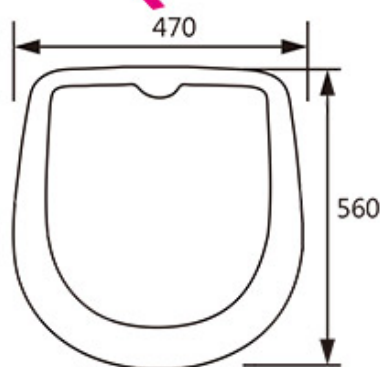

WJ-004
材質:PP/尼龍



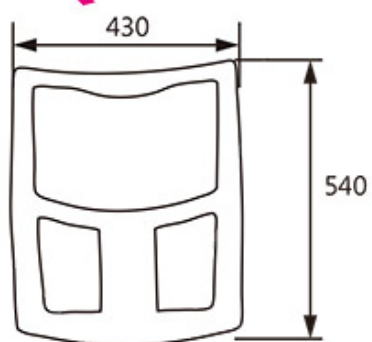

WJ-008
材質:尼龍+PP

43

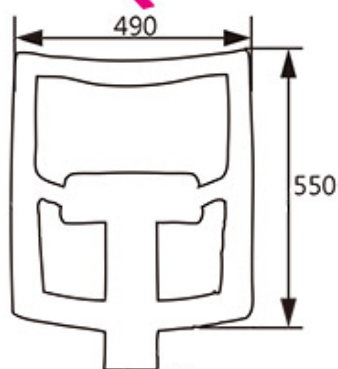

WJ-009
材質:尼龍+織

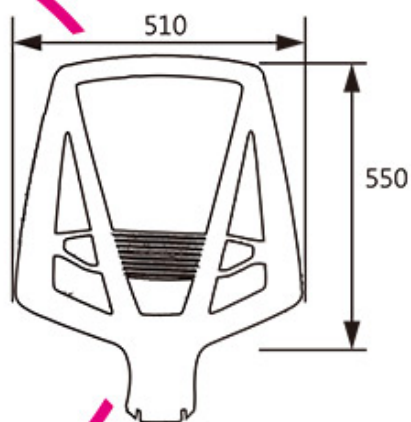

168A
材質:尼龍

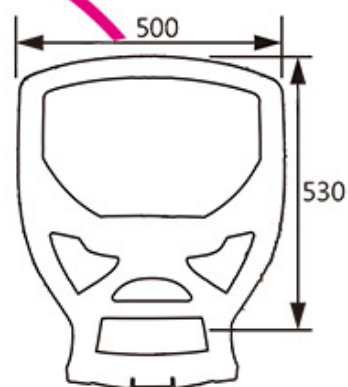

168B-B
材質:尼龍



SK-224
含一對扶手
材質:PP

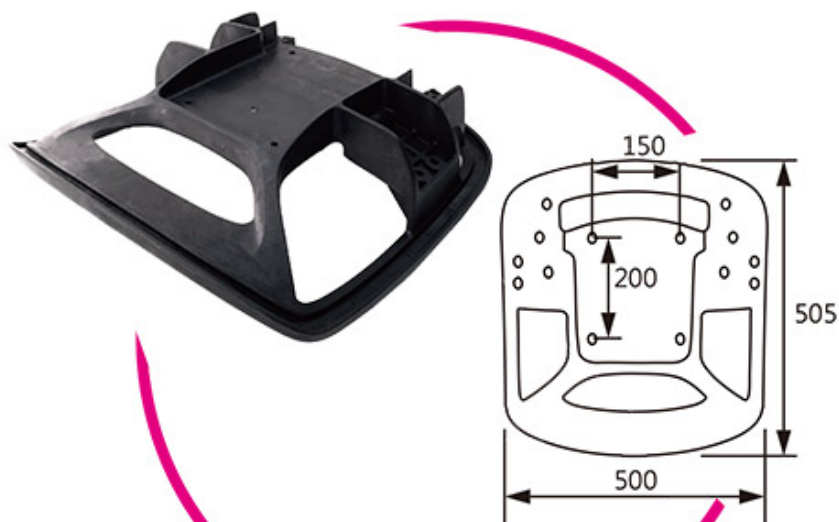

X-158
材質:尼龍

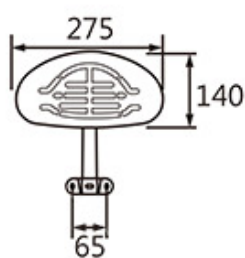

TVH-10B
材質:尼龍

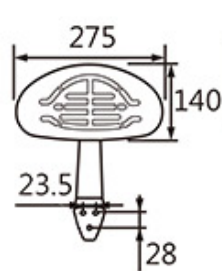

TVH-11B
材質:尼龍

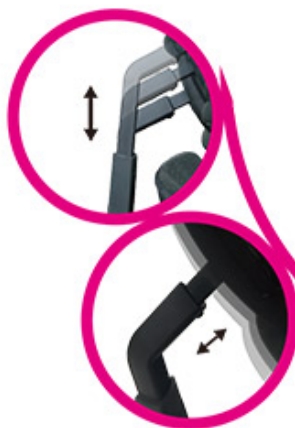

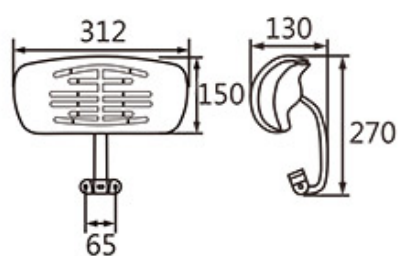

TVH-20B
材質:尼龍

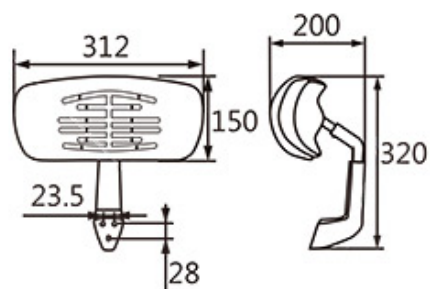

TVH-21B
材質:尼龍



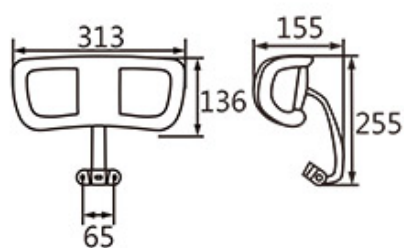

TVH-30B
材質:尼龍

48

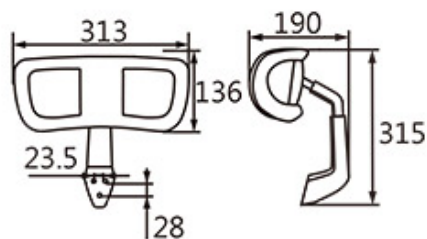

TVH-31B
材質:尼龍

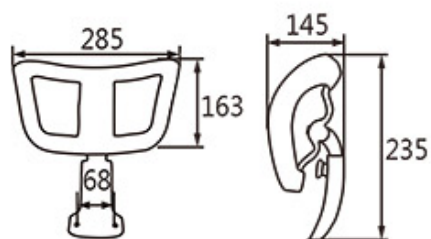

WJ-H01
材質:尼龍

49

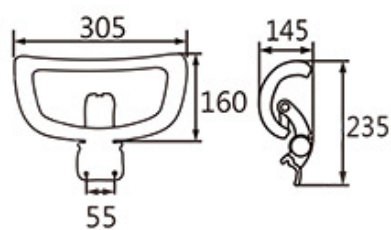

NC-04
材質:尼龍



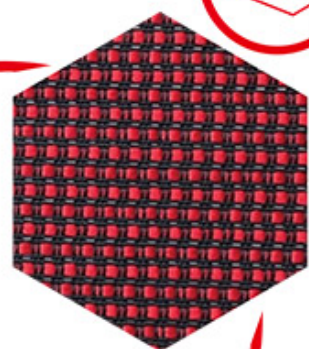
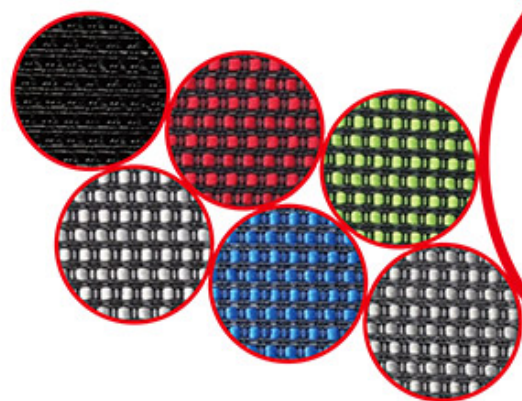

H160系列

幅寬:55"

材質:彈性紗46%

聚酯纖維54%

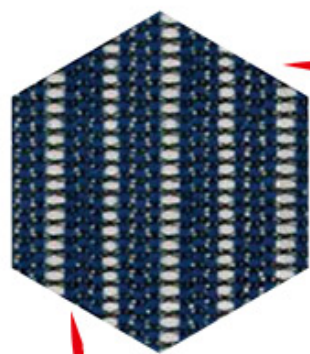

H154系列

幅寬:67"

材質:彈性紗75%

聚酯纖維25%

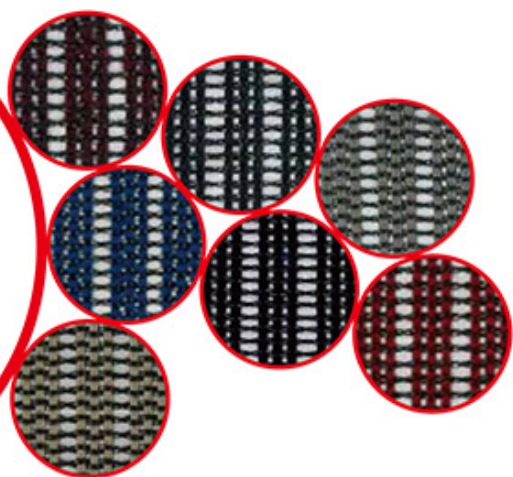

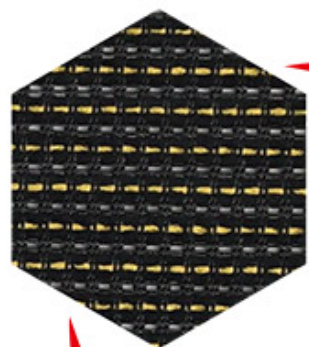

H146系列
幅寬:66"
材質:彈性紗40%
聚酯纖維60%

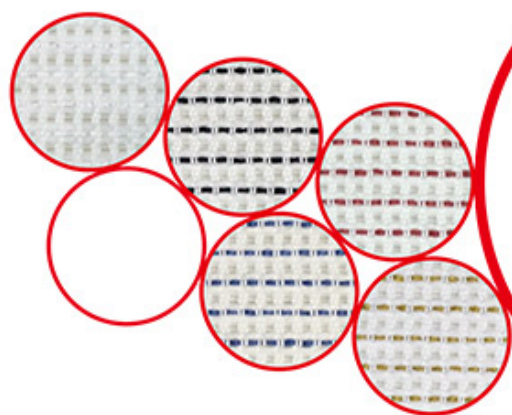

H147系列
幅寬:66"
材質:彈性紗40%
聚酯纖維60%

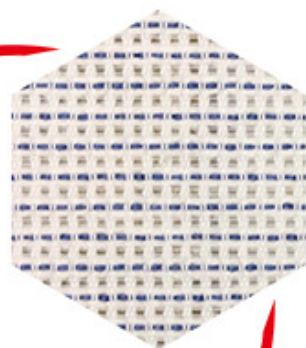

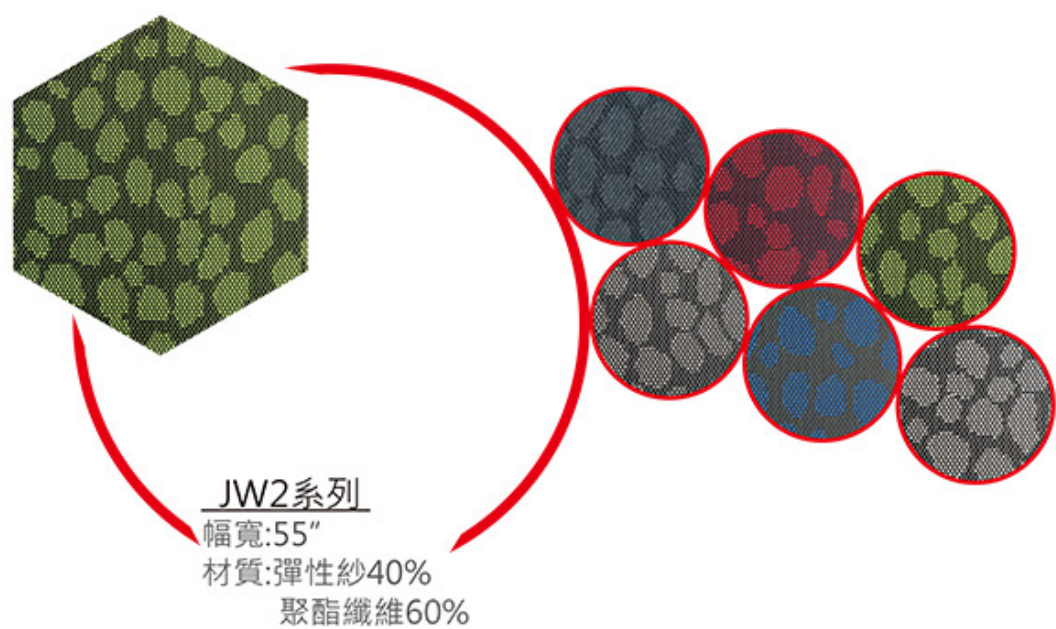
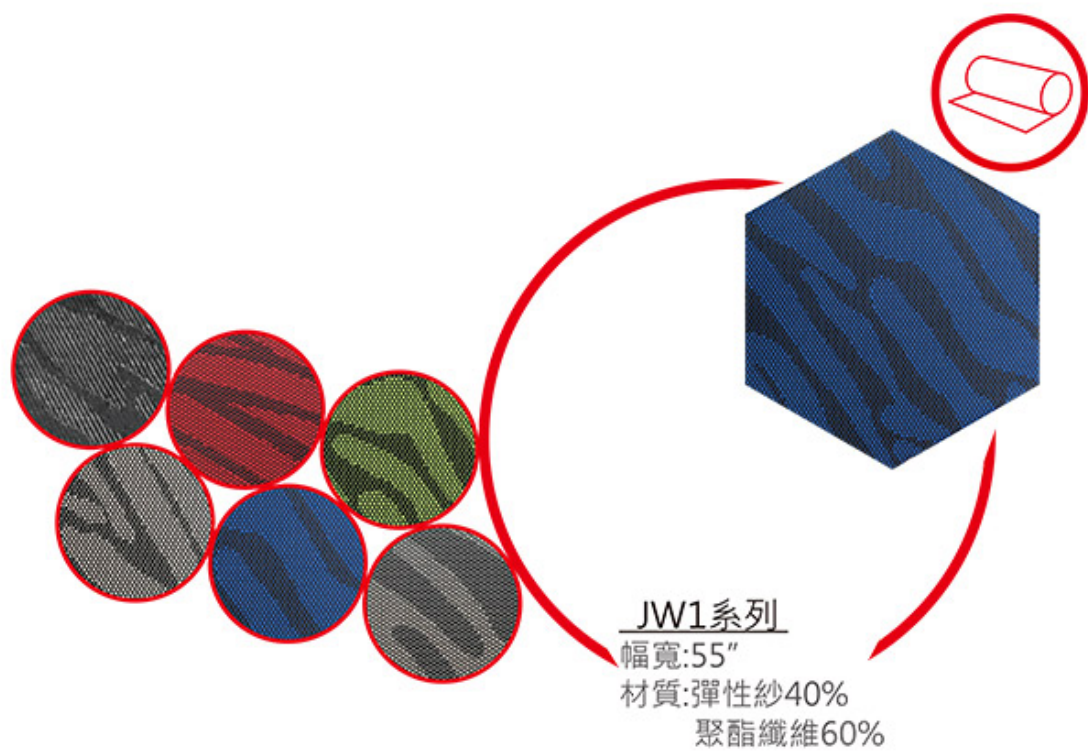

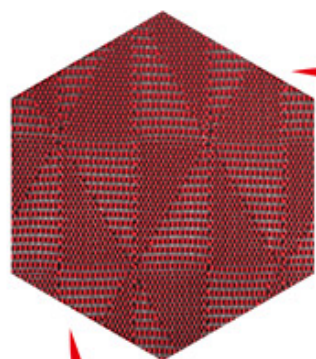

H192系列
幅寬:55"
材質:彈性紗65%
聚脂纖維35%

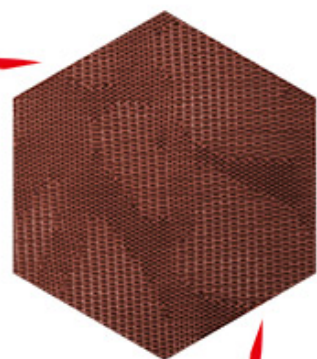
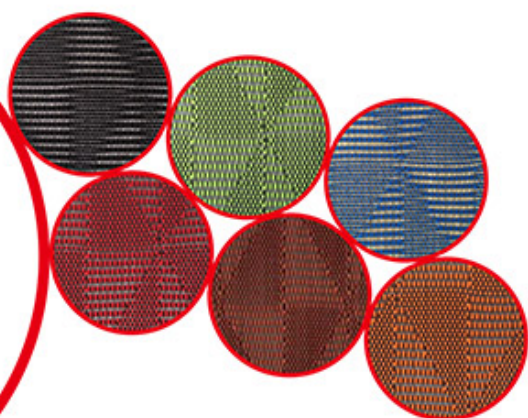

H194系列
幅寬:55"
材質:彈性紗65%
聚脂纖維35%

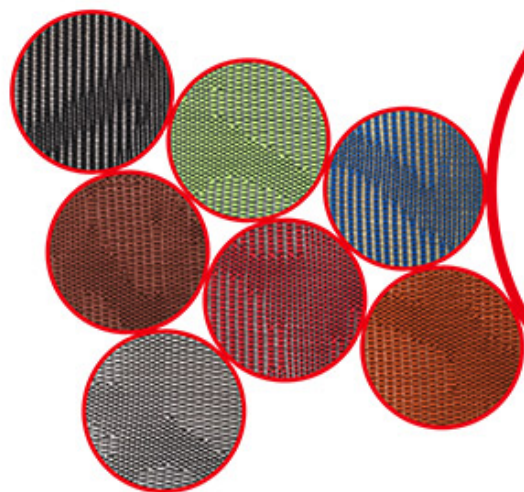

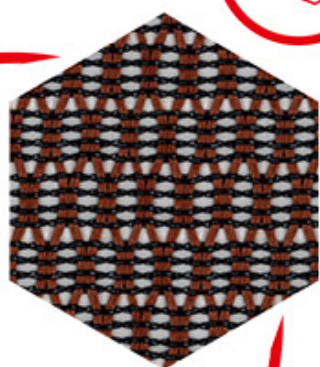

H138系列
幅寬:55"/67"
材質:彈性紗72%
聚脂纖維28%

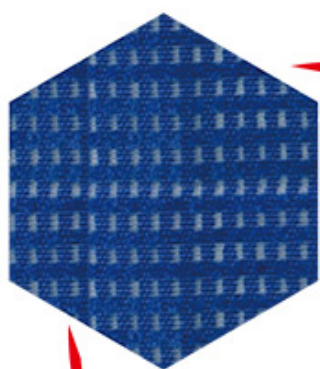

H139系列
幅寬:65"
材質:彈性紗50%
聚脂纖維50%

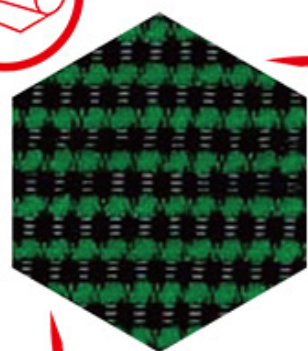

H141系列
幅寬:65"
材質:彈性紗50%
聚酯纖維50%

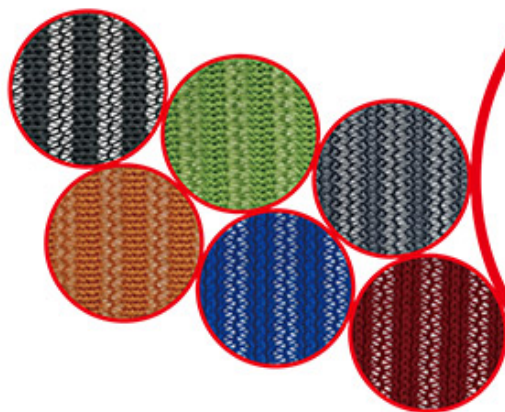
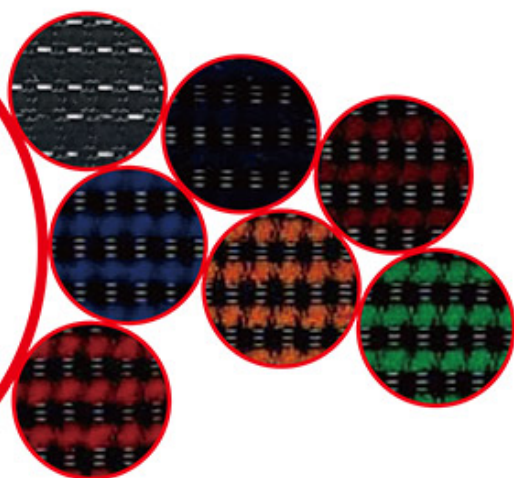

C074系列
幅寬:60"
材質:聚酯纖維100%

產品特色

市售網布差異化



網布幅寬



網布碼重(g)



彈性體粗細

網布

常規網布測試項目：

- 破裂度測試
- 撕裂強度測試
- 耐磨測試
- 加州防火測試
- 拉伸/抗張強度測試
- 耐光色牢度測試(日光色牢度)
- 磨擦褪色測試(乾溼磨擦)

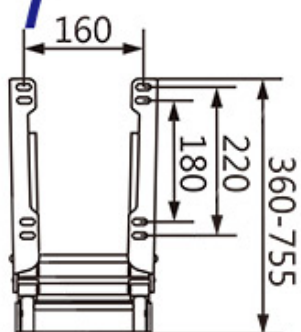

FR-001

材質:鐵+塑料



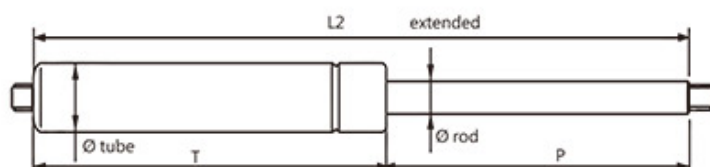

一般型氣壓棒 General Gas Spring

外管顏色：黑、銀

適用於各類掀門、器材收納

特色：提升產品方便性及舒適度

可依不同機構客製氣壓棒尺寸，並且有各式接頭可以搭配

Tube color: black, silver

Application: lift door, storage equipment, etc.

Feature: use the equipment more convenient and comfortable

Dimension can be customized, and there are various end fittings for selection

產品規格 Specification ※長度、壓力值、接頭皆可客製化生產 Length, force, end fittings can be customized

型號(德芝寶/德國) Type(TEC/Germany)	30-1/16-1	30-2/16-2	30-3/16-4	30-4/16-6	30-5
管徑 Ø tube(mm)	15	18	22	28	28
軸徑 Ø rod(mm)	6	8	10	12/14	16
※ 壓力值 force (N)	50-400	80-700	100-1200	200-2000	2800
※ 最大長 L2 max (mm)	600	700	800	800	700
※ 最小長 L2 min (mm)	100	300	300	300	300
兩端螺牙 Thread(mm)	M6*1.0	M6*1.0	M8*1.25	M8*1.25	M8*1.25

57 產品運用 Application



交通運輸 transportation
汽車引擎蓋 hood、後行李箱 truck



辦公設備 office equipment
印表機 printer、螢幕手臂 LCD arm



家具用品 furnishing
可收納沙發 storage sofa、
桌子 desk、櫃子 cabinet



工業設備 industrial equipment
機器掀門 lift door of machinery、
堆高機 forklift truck

Other application: 大型看板 huge billboard、排煙管 smoke ventilation window、跑步機 treadmill、
照明設備 lighting device、病床 hospital bed.....



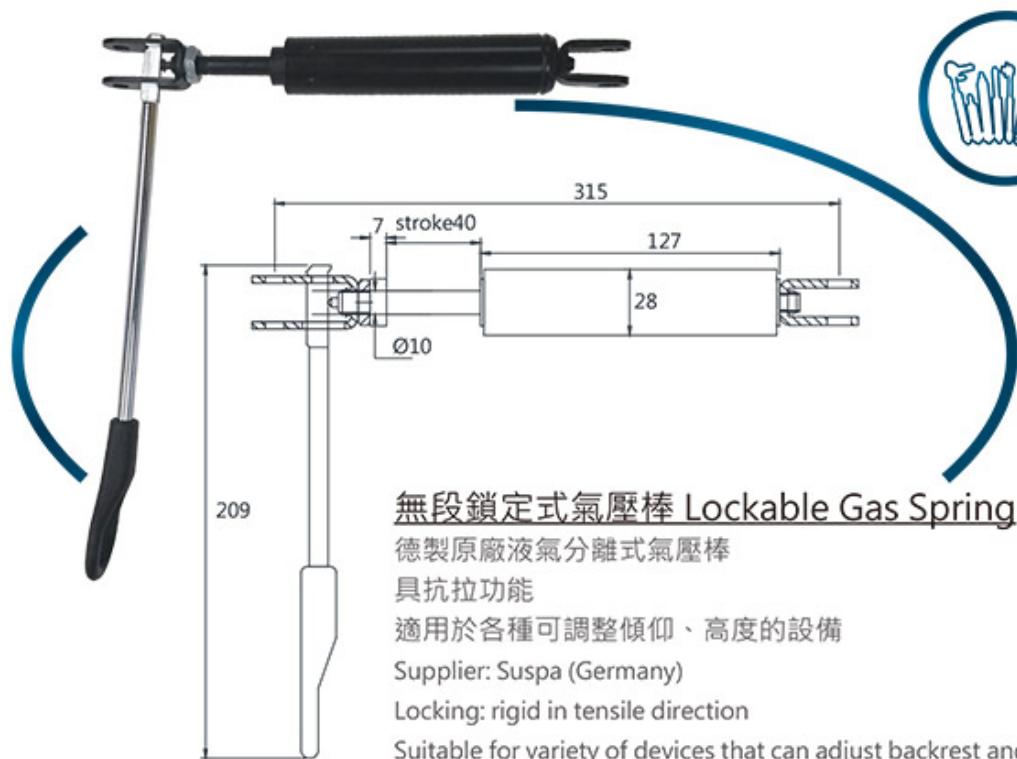

無段鎖定式氣壓棒 Lockable Gas Spring

德製原廠液氣分離式氣壓棒

具抗拉功能

適用於各種可調整傾仰、高度的設備

Supplier: Suspa (Germany)

Locking: rigid in tensile direction

Suitable for variety of devices that can adjust backrest and height.

產品規格 Specification

型號(德國) Type(Germany)	HY3
管徑 Ø tube (mm)	28
軸徑 Ø rod (mm)	10
壓力值 force (N)	400
	600
管長 Tube (mm)	127
行程 stroke (mm)	40

搭配接頭 Appendant End Fittings

桿端 Piston rod side

U701

開關柄(扁柄)(選配 optional)



管端 Tube side

U702

加長接頭 AE19, AE-15(選配 optional)



內部結構 Structure

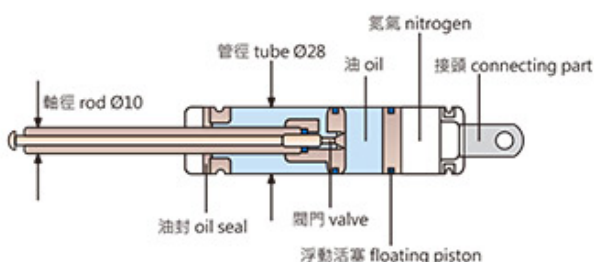

※詳細規格請參照第63、65頁

Regarding the detailed specification, please refer to page. 63, 65.

產品運用 Application 巴士椅 bus chair 病床 hospital bed 輪椅 wheelchair 運動器材 fitness equipment



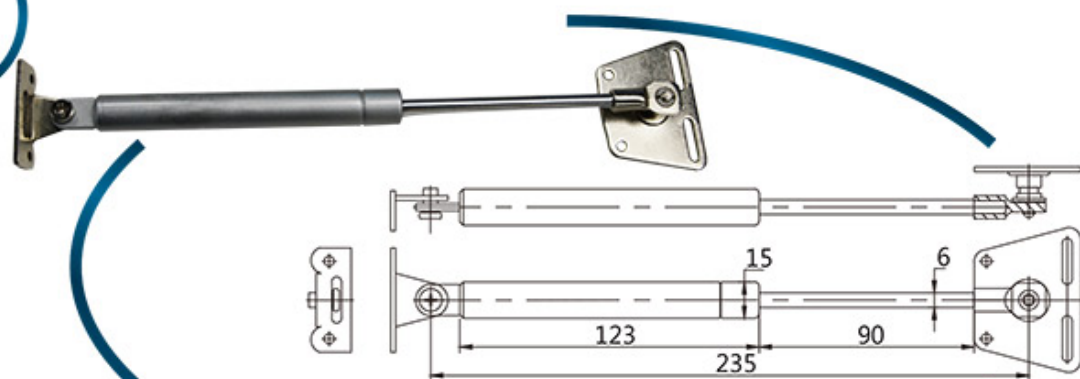

櫥櫃氣壓棒 Furniture Gas Spring

規格：外管 123mm、行程 90mm

外管顏色：銀色

適用於各種家用櫥櫃

Dimension: tube 123mm, stroke 90mm

Tube color: silver

Suitable for various furnishings, for example, cabinet.

產品規格 Specification

型號(德芝寶) Type(TEC)	30-1
管徑 \varnothing tube (mm)	15
軸徑 \varnothing rod (mm)	6
壓力值 force (N)	100
	150
	200
管長 T (mm)	123
行程 stroke (mm)	90

搭配接頭 Appendant End Fittings

管端 Tube side

桿端 Piston rod side

C1

C2



※詳細規格請參照第63頁

Regarding the detailed specification, please refer to page. 63.

安裝示意圖 Recommend application

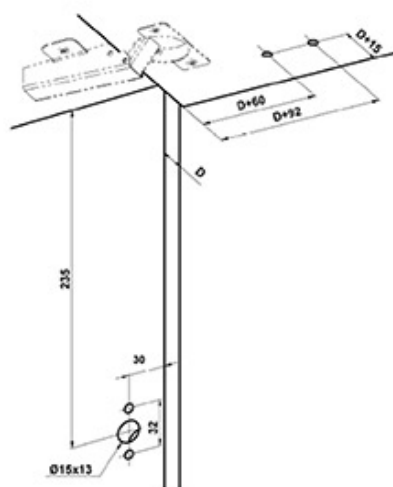

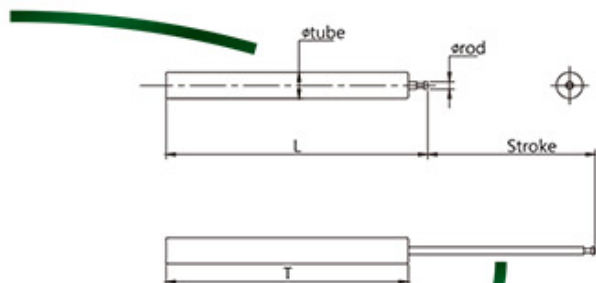

阻尼器 Damper

分為一般型及自彈式(內含彈簧)

整支材質為不銹鋼·與塑膠材質相比降低爆裂風險

純熟的抽管技術-管身一體成形·無接縫

管身採雷射雕刻刻印生產週期·有效管理歷程出貨品質狀況

可被安裝在各種設備上·以提升在推進、拉出、旋轉等運作方向的舒適度

Type : General, Auto spring (spring inside)

Material : Stainless steel (The risk of explosion is lower than plastic)

Proficient skill of drawn tube-Tubes integrated and seamless

There is a production date printed by laser on tube so that we can manage the quality of every shipment

Could be installed on hardware to improve the comfort in terms of pushing, pulling or rotating

產品規格 Specification ※阻尼值、尺寸皆可客製化生產 Dimension can be customized

款式 Type	I	II	III	IV	V	VI
管徑 Ø tube (mm)	7	7.8	10	12	15	15
軸徑 Ø rod (mm)	2	2	2.5	3	3	4
外管尺寸範圍 range of T (mm)	40-87	40-100	50-130	50-130	50-130	50-130
一般型內部配件空間 (mm) space of inside component-original	28	28	28	28	28	28
自彈式配件占用空間 (mm) space of inside component-auto spring	40	40	40	40	40	40
最大阻尼值 Max force	20	35	50	60	120	150

■行程=外管-內部配件占用空間

Stroke(mm)=T(mm) - The space of inside component(mm)

■阻尼值測試條件：30mm/sec

The testing condition of force: 30mm/sec



桿端關節軸承

德國 Durbal-專業軸承製造廠 ※詳細介紹請參照第62頁

高品質、超精密、堅固耐用

產品等級

優質型

經典型

基本型

Supplier: Durbal (Germany) ※ Regarding the detailed introduction, please refer to page. 62

Feature: quality, precision, robust

Product level

Premium

Classic

Basic

Premium Line 優質型



1.BRTF

2.BRTM/BRM

3.BRTF/BRF

4.BRF

5.PM

6.PF

7.

8.

9.



10.WLT

11.WLT/WLK

12.WLK

高荷重軸承
heavy-duty rod ends
No.1~6

客製化產品
Custom-made product
No.7

高荷重套件
Heavy-duty system
No.8~9

高荷重球型軸承
Heavy-duty spherical-plain
bearings
No.10~12

Class Line 經典型



1.BEM

2.BEM

3.BEF

4.EF

5.BEMN

6.BEMN

7.BEFN

8.EMN

9.



10.

11.

12.

高荷重軸承
heavy-duty rod ends
No.1~8

客製化產品
Custom-made product
No.9~12



Basic Line 基本型



標準軸承
Standard-rod ends
No.1~4

液壓軸承
Hydraulic-rod ends
No.5~6

客製化產品
Custom-made product
No.7~8

U型配件
Accessories/Clevis
No.9

球面軸承
Spherical-plain
bearing
No.10~12

Durbal-德國專業軸承製造廠 The professional rod ends manufacturer in Germany

■成立於1938年·擁有78年豐富的生產經驗

The company was established in 1938 with 78 years of experience

■庫存超過600種不同款式的軸承·且超過99%的訂單當天即可完成並且送出

With over 600 different styles and types of rod ends in stock, and over 99% of their orders are shipped on the same day.

■所有軸承都依照 DIN648 & ISO 9001/14001 製作·也是全球第一間獲得 IOS 9001認證的專業軸承製造商

Durbal rod ends are hand crafted to DIN 648 German Engineering Standards & ISO 9001 / 14001, they also the first rod end manufacturer Certified ISO 9001.

DURBAL



VISION
TECHNOLOGY

since
1938

產品目錄 product catalog





U型接頭

Clevis

Part No: **U701**

材質:鐵 Material: iron



Part No: **U702**

材質:鐵 Material: iron



Part No: **U703**

材質:鐵 Material: iron

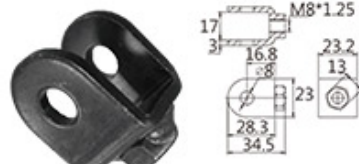

Part No: **U704**

材質:鐵 Material: iron



Part No: **U705**

材質:鐵 Material: iron



Part No: **U706**

材質:鐵 Material: iron



Part No: **U707(附勾)**

材質:鐵 Material: iron



Part No: **U708**

材質:鐵 Material: iron

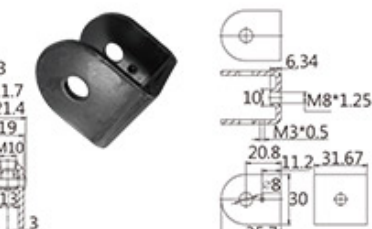

Part No: **U709**

材質:不鏽鋼 Material: sus 304

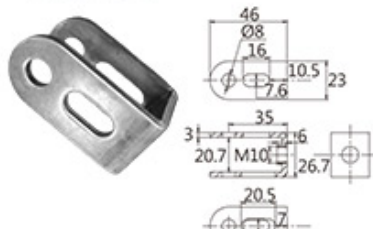

櫥櫃用接頭

Furniture gas spring end-fitting

Part No: **C1**

材質:鐵 Material: iron

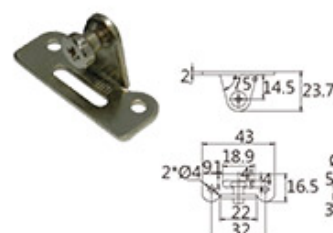

Part No: **C2**

材質:鐵 Material: iron

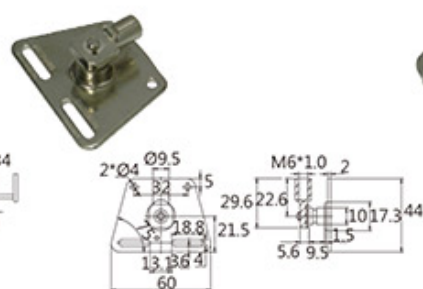

Part No: **C3**

材質:鐵 Material: iron



Part No: **C4**

材質:鐵 Material: iron





焊接鐵片 Welded iron

Part No: **Q11**

材質:鐵 Material: iron

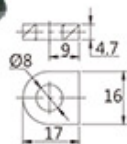

Part No: **Q13**

材質:鐵 Material: iron

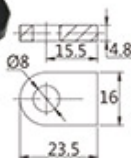

Part No: **Q14**

材質:鐵 Material: iron



Part No: **Q16**

材質:鐵 Material: iron

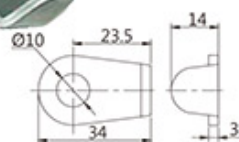

Q型接頭 Hinge head/eyes

Part No: **Q5**

材質:鐵 Material: iron

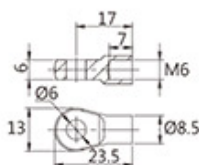

Part No: **Q4**

材質:鐵 Material: iron

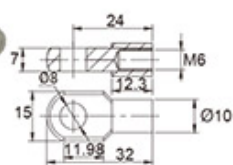

Part No: **A2-B2**

材質:鋅合金 Material: Zinc Alloy

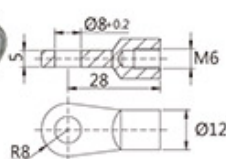

Part No: **Q2**

材質:鐵 Material: iron

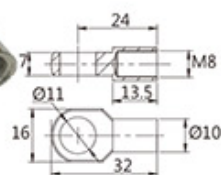

Part No: **Q3**

材質:鐵 Material: iron

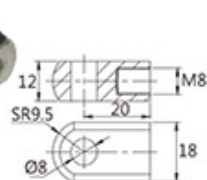

Part No: **A30**

材質:鋅合金 Material: Zinc Alloy

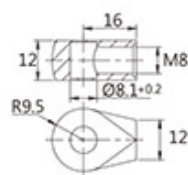

Part No: **A44**

材質:鋅合金 Material: Zinc Alloy

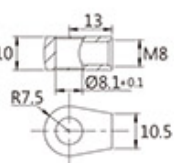

Part No: **A13-B13**

材質:鋅合金 Material: Zinc Alloy

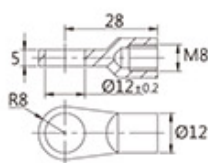



萬向接頭 Elbow joint

Part No: **A3**

材質:鐵 Material: iron

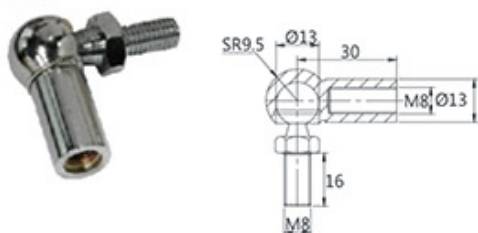

Part No: **C1501-M6 & M8**

材質:鐵 Material: iron

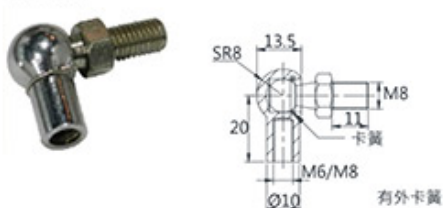

開關柄 Switch lever

Part No: **開關柄(扁柄)**

材質:鐵 Material: iron & plastic

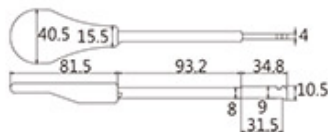

加長接頭 Elongate end-fitting

Part No: **AE-19/AE-45**

材質:鐵 Material: iron

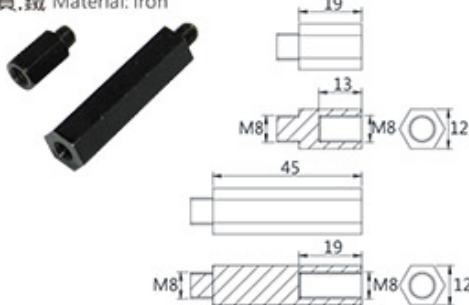

氣壓棒使用注意事項：

1. 內含高壓無毒惰性氣體(氮氣)·請勿自行將氣壓棒拆解·或置於高溫環境存放
2. 正常存放溫度環境為25°C·氣壓棒內部壓力隨外在溫度環境變化有所不同。
3. 氣壓棒存放溫度與工作環境溫度需維持於-20至+60°C·且氣壓棒本體運作時溫度不得高於60°C。
4. 正常存放環境下·即使氣壓棒未使用·內部壓力(F1)亦逐年減少。
5. 壓力(F1)公差為+40N/-20N·長度尺寸公差為±2mm。
6. 安裝時請將氣壓棒軸心向下安裝·以確保內部配件正常運作。
7. 安裝時兩端固定點不可晃動、歪斜·並確保氣壓棒直線運作、受力不平均·導致氣壓棒損傷。
8. 安裝及使用請注意氣壓棒本體與軸心不得碰傷、刮傷、油漆、汙漬·亦不得至於潮濕、灰塵、汗垢、高熱等環境·避免功能失效。
9. 氣壓棒屬客製化產品·目錄上尺寸僅供參考·可依要求提供訂製·但需避免以下兩種情形：
 - a. 管徑粗、行程長、壓力低。
 - b. 管徑小、行程短、壓力高。
10. 正常使用下·德製氣壓棒使用壽命50000次·保固期限為一年。

User Notice:

1. Gas spring is filled with non-toxic nitrogen at high pressure, please Do Not open or heat up.
2. The force (F1) of gas spring is different under different temperature environment. The normal temperature of storage is 25 °C.
3. Both working and storage environment should be maintained within -20°C~+60°C.
4. The force (F1) will decrease even the gas spring is unused or in storage every year.
5. The tolerance of force (F1) is +40N/-20N, and length is ±2mm.
6. To protect the packing of gas spring, please make sure the piston rod is downwards when the gas spring is used.
7. Please make sure the gas spring working on a straight line, and no slop or lateral force on the gas spring when using.
8. Please Do Not hit, paint, or scrape the gas spring. Please also Do Not expose to the rain, wet, high temperature and heavy duty environment.
9. Gas spring could be produced by your specification but please avoid such condition :
 - a. large tube, long stroke (piston rod), and low force(F1)
 - b. small tube, short stroke (piston rod), and high force(F1)
10. Germany gas spring have 50000 cycles within one year under normal condition.

01

WS-138 WS-07 TPU WS168



02

H626 H626-1 PU1828 PU1829



03

H634S1 +1834-4 H626-4 +PU1834S



04

CH-161PP CH-180 CH-163 NAPP CH-172 APP



05

WS-112 WS-122T WS-123S WS-126



06

WS-158 WS-158FT WS-378 WS-358S



07

AT-03A AT-15 JS-099



08

D02 D02AST D187 D278ST



09

D190 D65-1 WS801-2D WS801-3D



10

CF MS 98B



11

T738A T738C



12

T728SG T728A T728B



13

T727B T879SD



14

T718A T722A



15

T701W T711A



16

T892 T878-7



17

T879D-Z T879CSF



18

四方盤 T322 HL-025



19

常規氣壓棒
6.5cm-10cm

20

常規氣壓棒
12cm-26cm

21

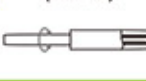
自動回位氣壓棒
(無升降)

22

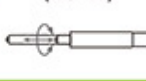
自動回位氣壓棒
(帶升降)

23

不旋轉氣壓棒



24

X350 P350 I300



25

AL-B330 B350/L350 AL-C19



26

AL-D300 AL-H300 AL-S325B



27

AL-J330 AL-S350 AL-H350



28

C320 AL-350 AL-R320



29

AL-X350 AL-320 電鍍 AL-B330 電鍍



30

AL-S325B 電鍍 AL-S350 電鍍 SM320 鐵腳



31

圓管腳圈 扁管腳圈



32

460腳圈 510腳圈



33

5005
BUG-E5006
BUG-386001
GUB-236005
BUB-386506
BUDG-23

34

6005
BUB-23-C5006
BUG-38SB
坐下不動5003
B-148KL6001
BUG-E BK6005
GUB-23BK

35

5003
B-38-C5003
B-385505
B-236001
B-236506
B-23

36

5006
BUG-38P6506
BUB-23P65F1
GUBL-23客制化
LOGO輪

37

CY 座板



38

APOLLO
高背APOLLO
中背

39

B817



HH-01



40

HH-02



HC-B02



41

HC-183



HC-189



42

WJ-001



WJ-004



43

WJ-008



WJ-009



44

168A



168B-B



45

SK-224



X-158



46

TVH-10B



TVH-11B



47

TVH-20B



TVH-21B



48

TVH-30B



TVH-31B



49

WJ-H01



NC-04



50

H160系列



H154系列



51

H146系列



H147系列



52

JW1系列



JW2系列



53

H192系列



H194系列



54

H138系列



H139系列



55

H141系列



C074系列



56

FR-001



57

一般型氣壓棒



58

無段鎖定式氣壓棒



59

樹櫃氣壓棒



60

阻尼器



61

BRTF/BRF



PM



PF



BEM



BEM



BEF



EF



62

DSA



DSSI



DPHS



63

U701



U702



C1



C2



64

Q16



Q4



A30



65

A3



開關柄

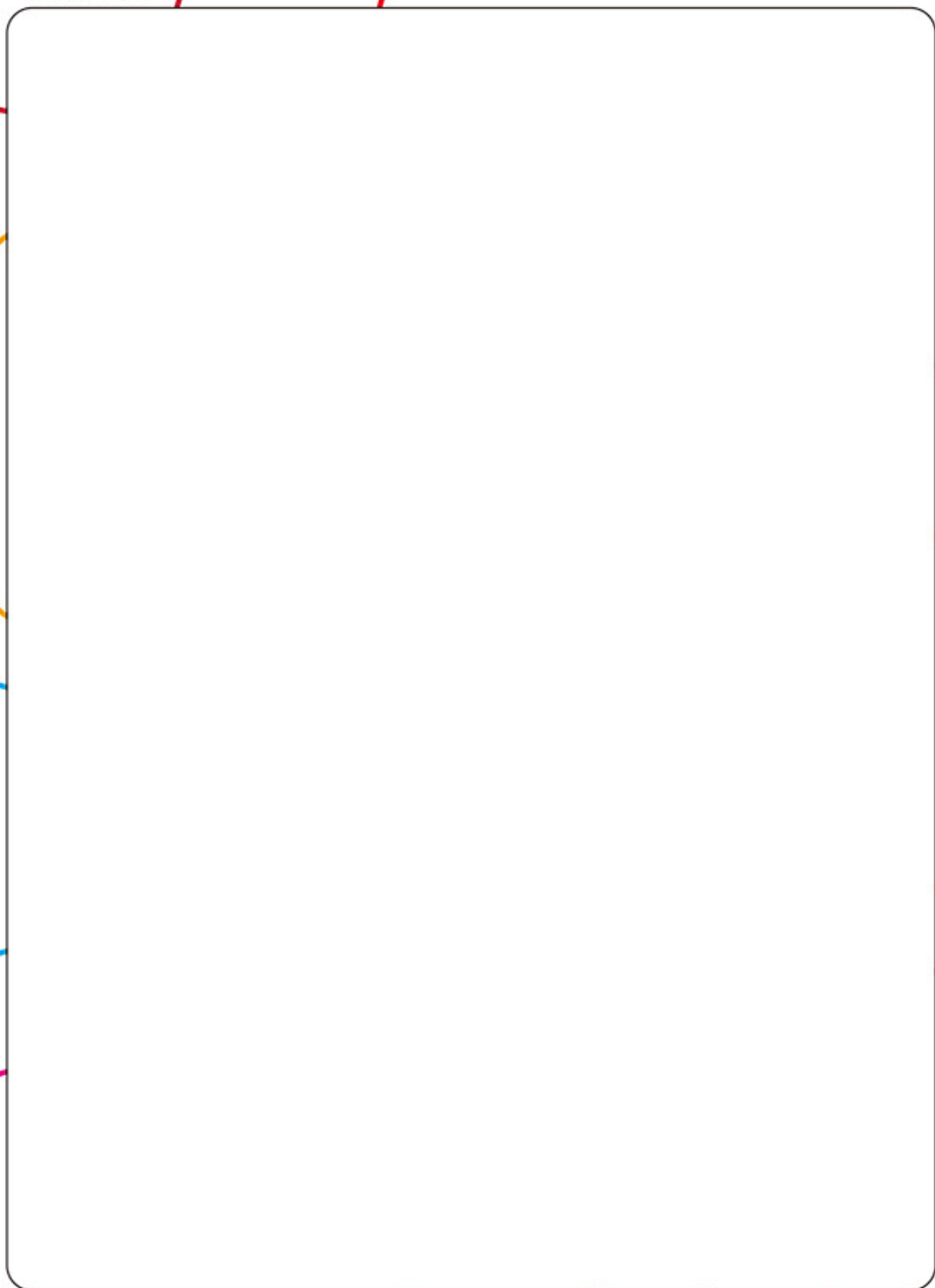

Note:

A large, empty rectangular box with rounded corners, intended for a note. The box is white with a thin black border. It is surrounded by colorful, curved lines in red, orange, blue, green, and yellow, which appear to be decorative elements or part of a larger graphic design.

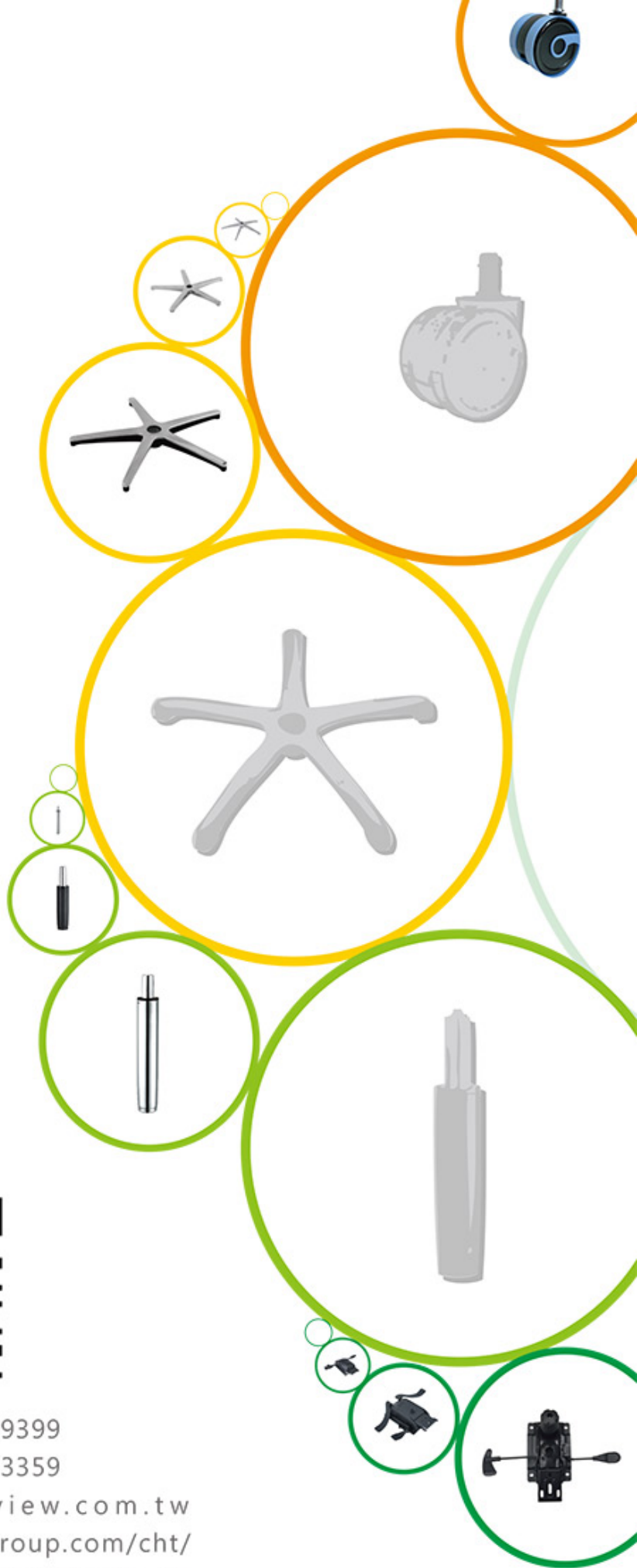

電話：+886-3-3619399

傳真：+886-3-3613359

E-mail：service@tecview.com.tw

網址：http://www.tecviewgroup.com/cht/

地址：33068桃園市桃園區大仁路50巷51弄58號